

RECOUP PIPE HEX ACTIVE-F INSTALLATION INSTRUCTIONS

INCLUDES THE RECOUP PIPE HEX RD ACTIVE-F

SHOWER WASTE WATER HEAT RECOVERY SYSTEM



Certificate No: 2012362

These instructions must be left with the user.

1. Introduction

These instructions are for the RECOUP Pipe HEX Active-F and RECOUP Pipe HEX Rd Active-F which use the RECOUP Pipe HEX and RECOUP Pipe HEX Rd Waste Water Heat Recovery Systems respectively combined with a SANIFLO Sanishower Flat pump. The RECOUP Pipe HEX Rd is a 1700mm reduced length and reduced performance version of the 2100mm RECOUP Pipe HEX. **Where these instructions refer to RECOUP Pipe HEX the same will apply for the RECOUP Pipe HEX Rd unless stated otherwise.**

The RECOUP Pipe HEX is a vertical Waste Water Heat Recovery System for showers (WWHRS). It recovers heat from the warm waste water as it passes through the unit, before going to the drainage system. The heat recovery is possible due to the double walled heat exchanger within the RECOUP Pipe HEX being manufactured from copper, a very effective material for transferring heat. The double walled exchanger gives full protection against any contamination between the waste water going out and the fresh potable water coming in. This preheated water then supplies the mains cold feed to the shower and/or a water heater (Combi-boiler, hot water storage cylinder, Thermal store or HIU).

The reason for doing this is to save money and energy. In an average shower, the water will come out of the shower head at 40°C, and the water going down the drain will only be a few degrees cooler than this. This energy has been paid for once, we believe at RECOUP that the home owner should get as much benefit from this energy before paying to heat more water. Whilst at the same time reduce the energy consumption and CO₂ emissions of the home.

The RECOUP Pipe HEX Active-F is a vertical heat exchanger combined with a SANIFLO Sanishower Flat pump designed to work on the same floor as the shower. For the products to be installed safely and perform optimally, it is very important to follow these instructions for the RECOUP Pipe HEX Active-F along with the separate instructions and "Important Additional Information" for the SANIFLO Sanishower Flat pump.

The RECOUP Pipe HEX Active-F should be installed by a suitably qualified plumber who gives consideration and attention to the system design as well as a correct installation. The electrical connection for the SANIFLO Sanishower Flat pump should also be carried out by a qualified person.

IMPORTANT - Standard Assessment Procedure (SAP)

For recognition of the RECOUP Pipe HEX energy saving performance within the National Calculation Method (NCM) for the energy rating of a new build dwelling within the UK (also known as the Standard Assessment Procedure (SAP)) it is vital that the pre-installation requirements (Section 3) and installation process (Section 4) contained in this installation manual are followed correctly and complied with fully.

An NCM (SAP) identifier label (already applied) is permanently fixed to the RECOUP Pipe HEX unit. A second label supplied with these instructions for application must be attached to a nearby water heater or service cupboard within the property. The 'model qualifier' section of the first label denotes the system installation method (A, B or C) and will state 'Refer to installation certificate **otherwise System B will be assumed.** The actual system installation method will be recorded on the installation / warranty certificate and the second NCM (SAP) identifier label. The second NCM (SAP) label applied within the property must be edited to record the installation method (A, B or C) when installed along with the product details.

2. Product technical data

2.a) General Information – RECOUP Pipe HEX Active

Description	Pipe HEX	Pipe HEX Rd
Overall height required for installation	2347 mm	1947 mm
Outside diameter of external tube	63 mm	
Material - Internal tube	Copper	
Material - External tube	PVC	
Shower flow rate range (when installed as System A)	5 - 15 Litres/min	
Max. Mains water inlet pressure	10 bar	
Min. Mains water inlet pressure	1 bar	
Max. Mains water working temp	40 °C	
Mains & Preheated water connection	½" female BSP	
Shower waste connection (Pump inlet / Pump outlet)	32 mm / 21.5 mm	
Soil waste water out connection	43 mm	
Water volume - mains water (WWHRS only)	0.3 Litres	0.24 Litres
Sanishower® Flat Pump Dimensions	295mm x 162 mm x 144 mm	
Sanishower® Flat Pump Voltage - Frequency	220-240V - 50-60Hz	
Sanishower® Flat Pump Noise Level	40 dB(A)	
Combined product weight (HEX 10kg, HEX Rd 8kg)	16 kg	14 kg

The mains water and preheat connections are a ½" female BSP connector which can be joined to either a 15mm pipe or a 22mm pipe with a reducer. The supplied waste water out reducer converts to 43mm solvent weld pipe.

2.b) Performance & Efficiency - Based on KIWA test data and PCDB figures for SAP 2012

Shower Flow Rate @ 40°C (Litres/min)	RECOUP Pipe HEX Efficiency (Recovered energy kWh)		
	System A	System B	System C
9.2	65.2% (10.88)		
11.0	63.6% (12.69)	49.9% (9.96)	54.0% (10.77)
12.5	62.5% (14.17)		

Shower Flow Rate @ 40°C (Litres/min)	RECOUP Pipe HEX Rd Efficiency (Recovered energy kWh)		
	System A	System B	System C
9.2	60.0% (10.01)		
11.0	57.3% (11.43)	45.3% (9.04)	49.6% (9.90)
12.5	55.5% (12.58)		

2.c) Pressure drop on main water circuit

Shower Flow Rate @ 40°C (Litres/min)	RECOUP Pipe HEX Pressure Drop (bar)		
	System A	System B	System C
9.2	0.39	0.24	0.16
12.5	0.67	0.41	0.27

Shower Flow Rate @ 40°C (Litres/min)	RECOUP Pipe HEX Rd Pressure Drop (bar)		
	System A	System B	System C
9.2	0.259		
11.0	0.361	0.219	0.185
12.5	0.441		

Pressure drop figures are based on 10°C cold water temperature, 40°C shower water and 60°C hot water.

3. Pre-installation requirement

3.a) Basic system principle

The RECOUP Pipe HEX is a Waste Water Heat Recovery System (WWHRS) for shower water, meaning it recovers heat from the warm waste water from a shower as it passes through before going to the drainage system for the property.

This preheated water then supplies the mains cold feed to the shower and the Domestic Hot Water (DHW) heater or in the case of system configurations System B and System C, the shower or the DHW heater respectively. The DHW heater could be, but is not limited to:

- Unvented hot water cylinder
- A combination boiler
- A thermal store or heat battery (Mains pressure DHW delivery)
- A Heat Interface Unit (HIU) on a district heating scheme (Mains pressure DHW delivery)

Note: The DHW heater must be a mains pressure system and able to accept preheated cold water.

3.b) Installation configuration

The inlet for the RECOUP Pipe HEX is connected to the mains water supply, and the outlet (preheated water) can be connected in one of three ways.

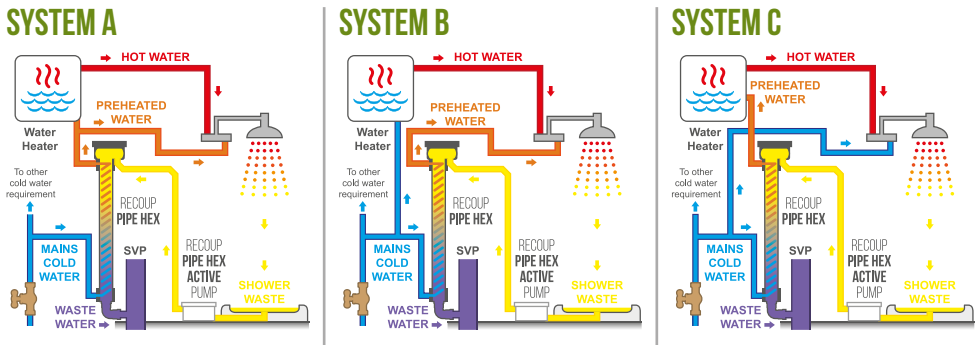

SYSTEM A – Preheated water supplied to shower mixer (Cold inlet) and DHW heater.

SYSTEM B – Preheated water supplied to shower mixer (Cold inlet) on the shower only

SYSTEM C – Preheated water supplied to DHW heater only

The performance of Systems A, B & C are all recognised within the SAP Products Characteristics Database (PCDB) for energy saving calculations, but remember that System A will produce the highest efficiencies (see section 2.b. for different system efficiencies).

3.c) Locating the RECOUP Pipe HEX Active

The RECOUP Pipe HEX needs to be installed vertically and is typically located alongside the SVP it is connected to. Installation of the RECOUP Pipe HEX should take place on a flat wall using the fixings provided. The SANIFLO Sanishower Flat pump needs to be installed at a height below the shower tray and shower tray determined by the distance between them and the depth of the shower trap and tray used.

IMPORTANT: There are distance constraints between the RECOUP Pipe HEX, SANIFLO Sanishower Flat pump, and the shower trap and tray as shown in the installation drawing in Section 4.

The SANIFLO Sanishower Flat pump can be boxed with the SVP and WWHRS, or separately. But access to the pump should be facilitated within this boxing. Please refer to Section 6 for all maintenance and access requirements.

The RECOUP Pipe HEX must be located within the heated envelope of the building.

The RECOUP Pipe HEX must be installed with consideration to the most recent 'Approved document – Part H of the Building Regulations' for preventing the ingress of foul sewer gases.

3.d) Design checklist

For recognition within the SAP calculations, the following must be complied with:-

- Consideration given to DHW delivery performance (Pressure & Flow rate)
- DHW system must be a mains pressure system
- DHW system must accept preheated water
- The RECOUP Pipe HEX must be located within the heated envelope of the building
- The shower must be fitted with a Thermostatic Mixing Valve
- Keep the distance from the waste water trap for the shower, or shower over bath, to the RECOUP Pipe HEX to within 3m where practically possible. This maintains a high level of efficiency by minimising heat loss in the drainage system prior to the WWHRS.
- The Preheated water supply from the RECOUP Pipe HEX to the shower cold water inlet and water heater must be:-
 - Insulated in accordance with the 'Building Services Compliance Guide'.
DO NOT INSULATE THE ACTUAL RECOUP Pipe HEX
 - Labelled to prevent any future connection of hot water take-off points (E.g. Taps).
 - As short as possible and no greater than 4.75m from the WWHRS to the shower TMV.
- Prevent the RECOUP Pipe HEX being heated above 25°C by both external sources and from ambient temperature.
- If shut-off valves are specified they should be 'full-flow (non-restricting) shut-off valves.
- Approved document – Part H of the Building Regulations has been consulted and an appropriate method for preventing the ingress of foul sewer smells chosen.

4. Installation of the RECOUP Pipe HEX Active

Check section 3.c) for guidance on locating a suitable area for installation.

Installation kit contents

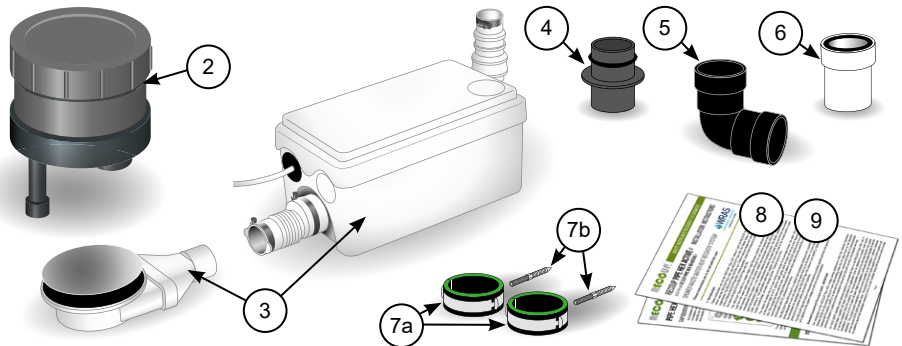

PART NUMBER KEY

- 1 - RECOUP Pipe HEX WWHRS unit - Ø63mm
- 2 - RECOUP Pipe HEX Active Buffer
- Ø50mm* to WWHRS
- Ø21.5mm* solvent from pump & trap
- 3 - SANIFLO Sanishower Flat pump
- 4 - Coupling insert - Ø50mm*
- 5 - 90° Coupling sleeve - Ø50mm*
- 6 - Ø50mm reducer*
- 7a - 2No. Mounting bracket - Ø63mm

- 7b - 2No. Bracket fixings - M8 x 100mm
- 8 - Installation instructions
- 9 - NCM (SAP) identifier label for nearby boiler or service cupboard.

*All Ø50mm parts are push-fit (50mm O/D European).
Item 2 requires a 21.5mm solvent weld pipe connection with a straight connector for the shower waste water from the pump. Item 6 reduces to 43mm UK solvent weld pipe for the soil waste.

YOU WILL NEED The following non-supplied parts...

2No ½" Male BSP brass connectors, 2No full bore lever shut-off valves, 1No double-check valve, 1No drain off valve, Thread sealant - Complying to The Water Supply (Water Fittings) Regulations, liquid recommended, 1No 21.5mm pipe straight connector, 21.5mm pipe & connectors (As required), & 1No Mcalpine ABSCON 32X1.25 connector if connecting the supplied trap to UK 32mm solvent weld pipe.

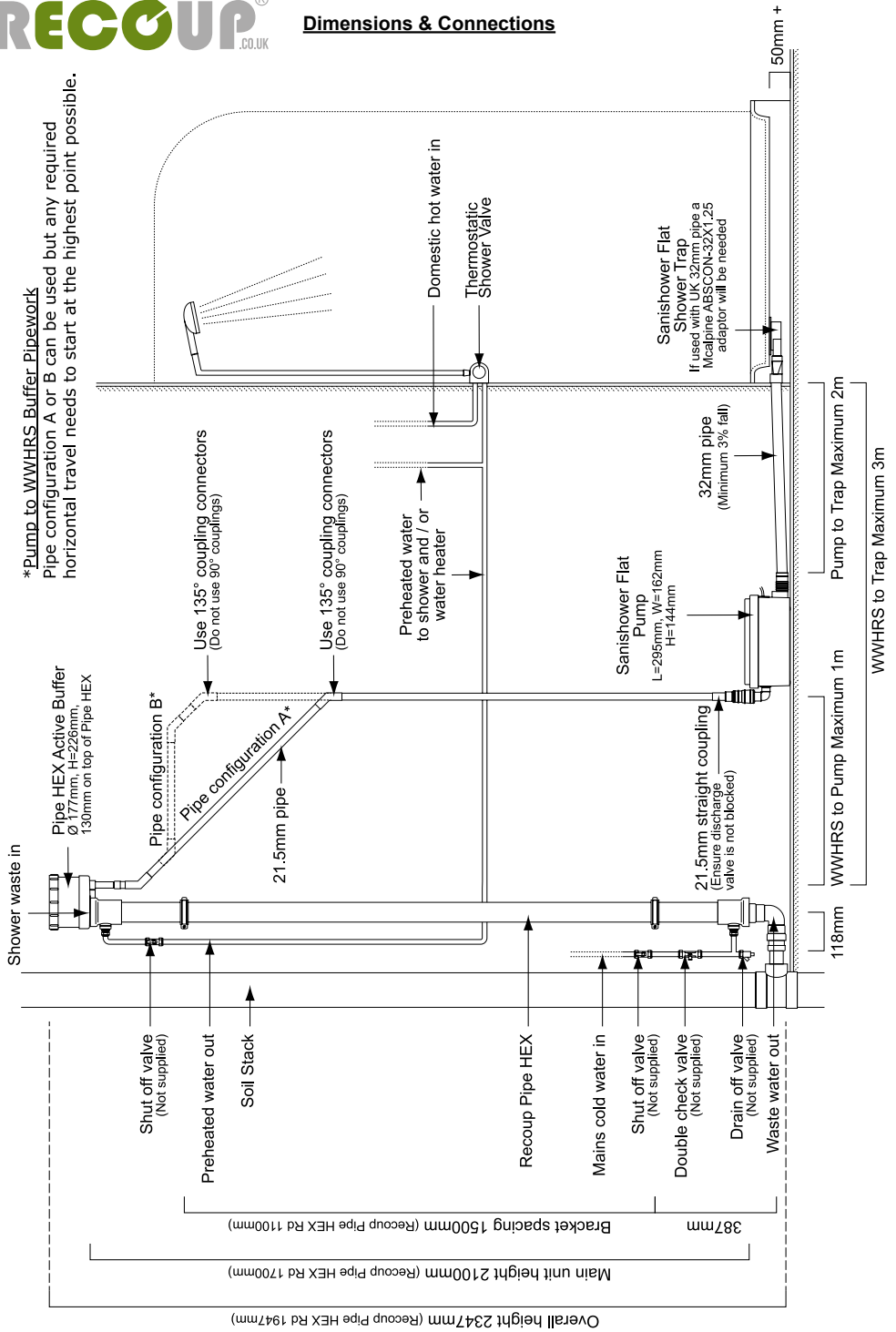

Installation process overview

While every effort is made to ensure this product arrives in optimum condition, please ensure you inspect the packaging and contents for any obvious signs of damage before installing the RECOUP Pipe HEX.

The unit must be installed vertically on a suitable flat wall which is capable of holding the weight of the unit. If the mounting is not vertical the efficiency of the unit could be reduced.

1. Starting 387mm above the centre of the soil waste connection, mark and drill in a straight vertical line two holes that are 1500mm apart (RECOUP Pipe HEX Rd 1100mm) to screw the wall mounting brackets into. Make sure there is adequate clearance top and bottom for the additional connections, and is at least 118mm horizontally from the soil waste connection. Timber battens should be installed if required.
2. Fix the mounting brackets (Part No.7a & 7b) to the wall, and locate the RECOUP Pipe HEX (Part No.1) into the wall brackets, with the highest wall bracket approx. 30cm lower than the top of the RECOUP Pipe HEX and the bottom bracket approx. 30cm above the bottom of the RECOUP Pipe HEX.
3. Check that the unit is in a vertical position (maximum tolerance of +/- 5mm).
4. Connect the coupling insert (Part No.4), 90° Coupling sleeve (Part No.5) and reducer (Part No.6) into the bottom of the RECOUP Pipe HEX and then connect the reducer (Part No.6) to the soil pipe. Part No.6 is supplied to reduce 50mm European to UK 43mm solvent weld waste pipe.
5. Insert the Recoup Pipe HEX Active Buffer (Part No.2) onto the top of the RECOUP Pipe HEX.
6. Use the "Dimensions & Connections" diagram, with the instructions and "Important Additional Information" supplied with the SANIFLO Sanishower Flat pump, install the pump. Electrical connection should be carried out by a qualified person. Connect the shower trap to the pump. The supplied trap requires a Mcalpine ABSCON-32X1.25 adaptor (Not supplied) for UK 32mm solvent weld waste pipe.
7. Install a 21.5mm straight coupling into the vertical pump outlet ensuring not to block the discharge valve within the vertical connector. Connect the straight coupling to the RECOUP Pipe HEX Buffer using 21.5mm solvent weld pipe. The pump can be positioned directly below the buffer, or as shown on the "Dimensions & Connections" diagram.
8. Connect the ½" female BSP cold mains water inlet (bottom) and preheat water outlet (top) in the RECOUP Pipe HEX to the mains cold and preheated water pipework using ½" male BSP brass connectors (Not supplied).

Tighten the connectors into the RECOUP Pipe HEX to a maximum of 30Nm.
IMPORTANT: Connections should be sealed using a suitable thread sealant complying to The Water Supply (Water Fittings) Regulations, liquid sealant recommended.

9. A double-check valve, full bore lever shut-off valve, and drain off valve (Not supplied) should be installed on the mains cold water supply prior to the WWHRS unit and another full bore lever shut-off valve (Not supplied) installed close to the connection for the preheated water leaving the WWHRS to facilitate any replacement of parts.
10. Check and complete the following:

- a) Ensure the preheated water supply is only feeding the DHW water heater and the cold water inlet of the shower's thermostatic mixing valve (System A), the cold inlet of the shower's thermostatic mixing valve only (System B) or the water heater only (System C).
- b) The preheated water supply from the RECOUP Pipe HEX is clearly labelled to avoid future connections of other services. Preheat supply tape is available for this.
- c) Pipework between the RECOUP Pipe HEX and the water heater and/or cold water inlet of the thermostatic mixing valve is insulated.
- d) The RECOUP Pipe HEX should be pressure tested after installation to a maximum of 10 bar. If the system requires testing above 10 bar the RECOUP Pipe HEX must be isolated for this additional testing.
- e) Ensure the SAP identifier label (Part No.9) supplied correctly identifies the System installed and serial number from the product label on the RECOUP Pipe HEX. Apply the label near the water heater in the property.
- f) Register the installation for SAP and guarantee requirements (Section 8).

Visit pipehexactive.recoup.co.uk or scan the QR code for all product information or to watch our installation videos.

For all technical or installation queries, please contact RECOUP directly. For product related issues, please contact your place of purchase.

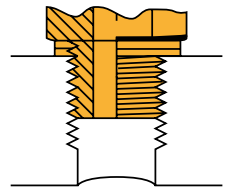

½" male BSP brass connector (Not supplied)
Tighten to Max 30Nm



Preheat supply tape (Not supplied)



SAP identifier label (Part No.9)



IMPORTANT NOTE

To ensure SAP compliance check buildings spec for correct installation method (System A, B or C)

Use 135° coupling connectors (Do not use 90° couplings)

SHOWER WASTE

PREHEATED WATER

Preheated water pipework

Full bore lever shut-off valve (Not supplied)

1/2" Male BSP connection (Not supplied) Tighten to Max 30Nm

1/2" Female BSP preheated water connection

7a 7b Timber batten

1500mm (RECOUP Pipe HEX Rd 1100mm)

7a 7b Timber batten

MAINS COLD WATER

Full bore lever shut-off valve (Not supplied)

Double check valve (Not supplied)

Cold water pipework

1/2" Female BSP mains cold water connection

1/2" Male BSP connection (Not supplied) Tighten to Max 30Nm

Drain off valve (Not supplied)

SOIL WASTE

Soil pipe

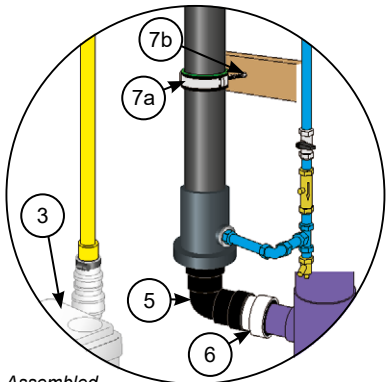
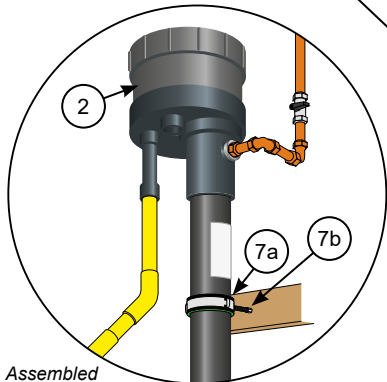

21.5mm pipe

21.5mm straight coupling (Ensure discharge valve is not blocked)

32mm pipe (UK 32mm pipe requires a Mcalpine ABSCON-32X1.25 adaptor, not supplied)

IMPORTANT NOTE

This document should be left with the home owners pack.

5. Water Safety, Legionella Risk & Protection

5.a) Double Walled Heat Exchanger

European regulations (EN 1717) require that double walls must be used to separate drain water and drinking water. In the RECOUP Pipe HEX, this is accomplished by squeezing two copper pipes against each other. This creates a very sturdy and reliable construction, in which the contact between the pipes does not depend on the water pressure. The design meets all the relevant safety requirements, and therefore does not require the trap to be moved from its usual position below the shower or bath.

The RECOUP Pipe HEX should be protected against return flow through a verifiable double check valve plus shut-off valve. It is permissible to connect the system directly to the SVP as shown in Section 4.

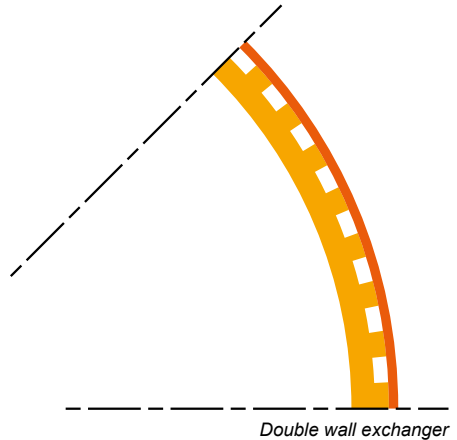

5.b) Legionella

Consideration must be given to the potential risks of legionella bacteria growth when installing any hot or cold water system and this includes ALL devices that are used in the production and transportation of hot or cold water in the domestic home or commercial environment. Please refer to the following information provided covering Legionella.

5.c) Legionella Risk & Protection when installing a RECOUP WWHRS product

Care and attention must be paid to the system design to protect against the potential risk of Legionella growth within the hot and cold water system with or without a WWHRS unit being installed. The guidance below is to highlight the potential risks that installation of a WWHRS can have on the hot and cold water supply within a property, but due to the variations in design in properties a final risk assessment needs to be carried out by the system designer and installer.

The following guidance is provided to keep the risk to a smaller level as possible, with general and specific guidance depending on the System of installation (A, B or C). Within the UK, there is no specific guidance on Legionella control within the domestic home, but the document known as HSG 274 and written for Health and Safety guidance in the work place, does in Part 2 offer guidance on the control of Legionella in water systems, some of which is aimed at recirculating hot water systems, but never the less offers good advice. The World Health Organisation (WHO) have also published a document (Last version 2007) titled 'Legionella and the prevention of Legionellosis', however, this is for information purposes only.

General guidance

For best practice the pipework between the WWHRS and the cold mixer on the shower and the boiler/hot water cylinder should be copper, as this is a material that is less susceptible to the formation of biofilm, which is a known factor in the growth of Legionella bacteria. However, if plastic / PVC plumbing has been considered suitable for the property by the installer/designer then an onsite risk assessment should be carried out to ensure the risk is minimal. If products do require flexible hoses instead of copper pipe then these must be PEX and never EPDM

It is always recommended to clean any TMV at least once every 6 months to remove the build-up of any contamination.

Showers in general can be a problem area for Legionella growth in the domestic home, and L8 recommends that shower heads are dismantled quarterly or as necessary to clean and descale them and the hoses.

The frequency that domestic showers are used in the home means that the system is flushed on a high number of occasions per week, which in itself helps in prevention of Legionella bacteria growth. It should be remembered that after any dormant periods (HSG 274 Part 2 recommends weekly flushing is acceptable as long as a risk assessment does not identify a susceptible population), it is good practice for a shower (With or without a WWHRS fitted) to be slowly flushed taking care not to create an aerosol, either by unscrewing the shower head or covering the shower head with a plastic bag and allowed to run for 3 minutes to introduce fresh water into the system. The hose on a shower from the TMV to a shower head will contain a mixture of cold and hot water, and the warming of the cold water brings it into the optimum temperature range for Legionella growth (TMV is set by the user between 36°C and 41°C). This water will cool down in time and in the domestic home be flushed through on a near daily basis, but it still introduces a risk.

System A – Delivery of preheated water to a water heater (Cylinder, combi-boiler, HIU) and the cold mixer on the TMV

If the water heater being installed is a hot water cylinder that will raise the temperature to 60°C for a period longer than 10 minutes, then the distance of pipe from the WWHRS to the cylinder doesn't matter with regard to Legionella, as the preheated water in the pipe will on entering the cylinder be raised to sufficient temperature to kill any bacteria (Note: that for energy efficiency this distance should still be kept to a minimum).

If a combination boiler or HIU (Heat Interface Unit) is being used then it should be capable of heating the preheated water to 60°C and holding it at that temperature for greater than 10 minutes, so any potential growth within stagnant pre-heated water from the previous shower is raised to a level where the Legionella bacteria can be killed. Any water heater used in the domestic home that does not raise hot water above 60°C for this period of time is introducing the same level of risk to the system (With or without a WWHRS), and these risks need to be assessed in terms of the level and frequency of usage, and whether the device is used for stored or instantaneous hot water.

SYSTEM A

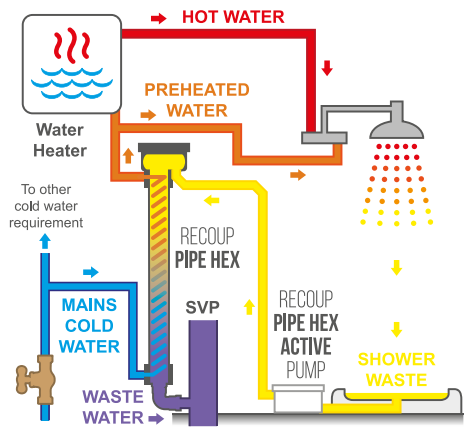

For System A there is also a feed of the pre-heated water straight to the cold inlet of the TMV. Regardless of the water heater that is installed in the installation, the pre-heated water (25°C) that remains between the WWHRS and the TMV will not be re-heated, so can never pass a temperature of 60°C, and therefore introduces the same level of risk to the system as any instantaneous water heater that does not achieve 60°C would do. HSG 274 Part 2 recommends that all cold water supplies should be kept to 20°C or below, however, it does note that the Water Supply (Water Quality) Regulations do permit water utilities to supply water to premises at temperatures up to 25°C, but due to the climate in the UK this is not likely, except in summer. Table 3: Monitoring the temperature control regime, of HSG 274 Part 2 states that the standard to meet for cold water on a monthly basis is that a temperature of below 20°C should be reached after running the water for up to 2 minutes. Therefore, it is suggested that the pipe run from the WWHRS to the cold inlet of the TMV is kept as short as possible, and no greater than 4.75 meters.

Users of the shower could additionally run the shower for 15 seconds after showering on the cold setting of the TMV to flush through the remaining pre-heated water. As mentioned in the general section, the regular use of showers in the domestic home means flushing happens on a regular occasion, however, prior to periods of non-use (E.g. Holiday), this practice would be advisable.

5.c) Legionella Risk & Protection continued from reverse pages ◀

To further protect the system from potential risk of legionella growth, the installation of a device from Kemper (KHS-Multi-Circ Distributor Unit) will reduce the amount of stagnation that occurs in the pre-heated pipe from the WWHRS to the cold inlet of the TMV, as each time a hot water outlet in the property is opened a small circulation will be created within the water (basic details below, and more information on www.kemper-valves.com)

The flow distributor's operation is based on the principle of the Venturi nozzle. The minimum pressure difference between Supply line A and Return line B causes an induced flow in the branch. The drive comes from water removal after the KHS-Multi-Circ Distributor Unit. The entire water content in the branch is thus changed, stagnation is prevented and the water temperature is kept low.

Taken from...

http://www.kempervalves.com/pdf/pdf%20englisch/khs_20s_engl_07_10.pdf

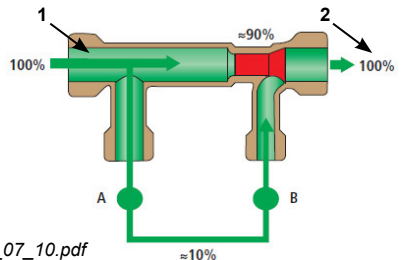

1. The pre-heated water from the WWHRS before it splits to the water heater and the cold inlet of the shower TMV.
- A. The split of the pre-heated water, with 'A' going to the water heater and the cold inlet of the TMV for the shower.
- B. A return loop taken from as close to the TMV as possible and back into the valve
2. Continues to the water heater

System B Installation – Cold inlet on the TMV only

This installation provides the highest risk of the three installation methods.

Regardless of the water heater that is installed in the installation, the pre-heated water (25°C) that remains between the WWHRS and TMV will not be re-heated, so can never pass a temperature of 60°C, and therefore introduces the same level of risk to the system as any instantaneous water heater that does not achieve 60°C would do. HSG 274 Part 2 recommends that all cold water supplies should be kept to 20°C or below, however, it does note that the Water Supply (Water Quality) Regulations do permit water utilities to supply water to premises at temperatures up to 25°C, but due to the climate in the UK this is not likely, except in summer. Table 3: Monitoring the temperature control regime, of HSG 274 Part 2 states that the standard to meet for cold water on a monthly basis is that a temperature of below 20°C should be reached after running the water for up to 2 minutes. Therefore, it is suggested that the pipe run from the WWHRS to the cold inlet of the TMV is kept as short as possible, and no greater than 4.75 meters.

It should be noted that the pre-heated water is never stored and maintained at the 25°C temperature, therefore, even though still a risk to consider if the system is to be used/flushed frequently this will be in line with guidance in HSG 274 Part 2 for treatment of the mixed water after the TMV which is also water containing cold water that has been heated above 20°C but not past 60°C (Along with the guidance in the general section for general maintenance of a shower with or without a WWHRS installed).

Users of the shower could additionally run the shower for 15 seconds after showering on the cold setting of the TMV to flush through the remaining pre-heated water. As mentioned in the general section, the regular use of showers in the domestic home means flushing happens on a regular occasion, however, prior to periods of non-use (E.g. Holiday), this practice would be advisable.

SYSTEM B

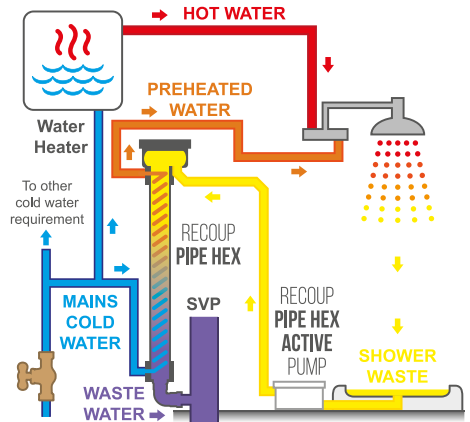

System C Installation – Feed to water heater only

This is the lowest risk of all the installation methods.

If the water heater being installed is a hot water cylinder that will raise the temperature to 60°C for greater than 10 minutes, then the distance of pipe from the WWHRS to the cylinder doesn't matter with regard to Legionella, as the preheated water in the pipe will on entering the cylinder be raised to sufficient temperature to kill any bacteria (Note: that for energy efficiency this distance should still be kept to a minimum).

If a combination boiler or HIU (Heat Interface Unit) is being used then it should be capable of heating the preheated water to 60°C and holding it at that temperature for greater than 10 minutes, so any potential growth within stagnant pre-heated water from the previous shower is raised to a level where the Legionella bacteria can be killed. Any water heater used in the domestic home that

does not raise hot water above 60°C for this period of time is introducing the same level of risk to the system (With or without a WWHRS), and these risks need to be assessed in terms of the level and frequency of usage, and whether the device is used for stored or instantaneous hot water.

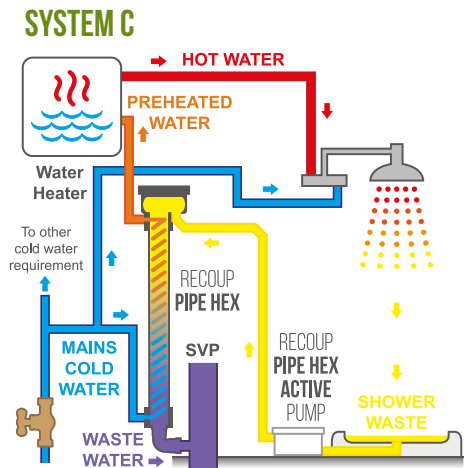

6. Maintenance & Access

There is no planned maintenance for the Recoup Pipe HEX or the SANIFLO Sanishower Flat pump. The SANIFLO Sanishower Flat pump may require descaling depending on water hardness. Please refer to the "Important Additional Information" supplied with the SANIFLO Sanishower Flat pump.

For the Recoup Pipe HEX in normal circumstances, the flow rate of the waste water should not allow any residue to build up. If a blockage forms elsewhere in the shower waste pipework, or in the very unlikely event of build up within the WWHRS, it is recommended to use the same cleaning and declogging process as detailed in the "Important Additional Information" supplied with the SANIFLO Sanishower Flat pump.

The SANIFLO Sanishower Flat pump must be easily accessible for checks and maintenance. Please refer to the "Important Additional Information" supplied with the SANIFLO Sanishower Flat pump. Access through normal use should not be required for the RECOUP Pipe HEX, but could be obtained with a pipe cleaning brush via the removable lid of the RECOUP Pipe HEX Active Buffer if there is access to it.

7. Warranty

The RECOUP Pipe HEX comes with a 10 year warranty. This starts from either the date of invoice from Recoup Energy Solutions Ltd or purchase from partnered trade distributors. Installation registration should be completed as part of the guarantee requirements.

This warranty is conditional on the product being installed in accordance with these instructions (Installation and ALL requirements for SAP, if product is to be recognised for Energy Efficiency Calculations), correct plumbing practices and Building Regulations.

The SANIFLO Sanishower Flat pump comes with a 2 year warranty. Please refer to the "Important Additional Information" supplied with the SANIFLO Sanishower Flat pump.

8. Registration

Please register this installation for SAP and guarantee. See the accompanying SAP identifier and installation registration document for further details.

9. Accidental Damage Assurance

The RECOUP Pipe HEX has a no quibble assurance for accidental damage covering the WWHRS unit only, this excludes ancillary components & pumps. If accidentally damaged we will provide a £75.00 credit, through our merchants, for exchangers that are returned in good condition. Please refer to our Terms and Conditions for full details of the accidental damage assurance provided. Terms and Conditions are available on recoup.co.uk or by contacting us.

WASTE WATER HEAT RECOVERY FOR SHOWERS

PLEASE REGISTER THIS INSTALLATION

The installation of this WWHRs should be registered for SAP and guarantee requirements.

Visit our website registration page
REGISTRATION.RECOUP.CO.UK
or scan the QR code.



RECOUP PIPE HEX IS **100% RECYCLABLE** AT END OF LIFE

Visit our website recycling page for more information

RECYCLE.RECOUP.CO.UK

Recoup Energy Solutions Ltd, Trumpeter House,
Trumpeter Rise, Long Stratton, NR15 2DY

T: 01379 844010

E: TECHNICAL@RECOUP.CO.UK

W: RECOUP.CO.UK



PIPE HEX ACTIVE SAP IDENTIFIER LABEL & INSTALLATION REGISTRATION

SAP IDENTIFIER LABEL

As detailed in the accompanying RECOUP Pipe HEX Active instructions, this peel-out label should be completed with the product version, serial number, and amended under model qualifier to correctly identify the system installation method installed. Tick which RECOUP Pipe HEX model is installed, write on the serial number, and delete the two incorrect system types.

Cut line

 WRAS APPROVED PRODUCT Certificate No: 2012362 PIPE HEX ACTIVE Pumped Vertical Shower Waste Water Heat Recovery	NCM (SAP) IDENTIFIER	RECOUP Pipe HEX (2.1m) <input type="checkbox"/> RECOUP Pipe HEX Rd (1.7m) <input type="checkbox"/>	<input type="checkbox"/> Tick one Recoup Energy Solutions Ltd, Trumpeter House, Trumpeter Rise, Long Stratton, NR15 2DY
	Serial Number: _____ Technology type: _____ Technology category: _____ Brand name: _____ Model qualifier: _____	SN: Waste Water Heat Recovery System Instantaneous Shower Heat Recovery RECOUP System A / System B / System C Delete as appropriate	
This dwelling has been fitted with a Waste Water Heat Recovery System for Showers which is recognised by the Government's Standard Assessment Procedure (SAP) for Energy rating of dwellings. Note: One label must be permanently fixed to the WWHRs unit and another to a nearby Boiler or Service Cupboard.			
<p style="text-align: center;"> PLEASE REGISTER for SAP and guarantee requirements. Visit our website registration page registration.recoup.co.uk END OF LIFE 100% product recycling available. Visit recycle.recoup.co.uk </p>			

The serial number is on the label attached to the RECOUP Pipe HEX. Once complete peel out the label, and apply it on or next to the water heater in the property. This process forms an important part of the SAP requirements for waste water heat recovery.

PLEASE REGISTER THIS INSTALLATION

INSTALLATION REGISTRATION

The installation of the RECOUP Pipe HEX Active WWHRs should be registered for SAP and guarantee requirements. Registration can be completed by submitting an online installation registration form. Visit registration.recoup.co.uk or scan the QR code to access the form.



Once submitted you will receive your installation registration certificate by email.

Visit our website registration page or scan the QR code

REGISTRATION.RECOUP.CO.UK